



Item	CHARACTERISTICS	Unit	EWC-T-D-R-0050-2015
1	Manufacturer		EWC
2	Rated power	kVA	50
3	Rated frequency	Hz	50
4	Rated. MV wind. voltage	kV	11
5	Steps of regulation on the MV side off-load	%	± 2 x 2,5
6	Rated LV wind. Voltage No-load	kV	0,416
7	MV/LV wind. connections		Delta/star+N
8	Vector group		Dyn11
9	Max altitude on the sea level	m	1000
10	Min. ambient temperature	°C	-5
11	Max ambient temperature	°C	50
12	Average yearly ambient temperature	°C	30
13	Type of installation		Indoor
14	Type of cooling		AN / AF
15	Dielectric		Epoxi-resin
16	Construction standards		IEC 60076-11
17	Isolation class of MV windings	kV	12/28/75
18	Isolation class of LV windings	kV	1,1/3
19	Thermal class of isolement		F
20	Average temp rise of HV/MV windings	°C	90
21	Max temp magn. core	°C	90
22	No-load losses to Vn	W	350
23	No-load current to Vn/110% Vn	%	3.0
24	Load-losses ref. To 75°C	W	880
25	Impedance ref. To 75°C	%	6
26	Sound Power level	dBA	60
27	Efficiency		
	100% Pn cos φ= 1	%	97.59
	75% Pn cos φ= 1	%	97.79
	50% Pn cos φ= 1	%	97.77
28	Total weight	Kg	490
29	Dimensions: in plant (LxP)	mm	1180x650
	Height (H)	mm	1040
	Interdistance of wheels (I)	mm	520

Fittings and Accessories:

- Dial electronic thermometer with two electric. n.o. contacts.
- n.3 thermal resistance tp.PT 100 with junction electrical box.

Other Accessories:

- On demand.

REGIONE	00	EMISSIONE		ELABORATO	T. AL-SALHI	CONTROLATO	T. AL-SALHI	APPROVATO	T. AL-SALHI
DATA		DESCRIZIONE							

EWFC GROUP srl

028766
 Via
 Casti resin Dist. Tronci / Tronci di Dist. in resina
 50 KVA - 11/0,415kV

COMMESSA
 R/E /E

INSENO
 R/R
 1 di 2

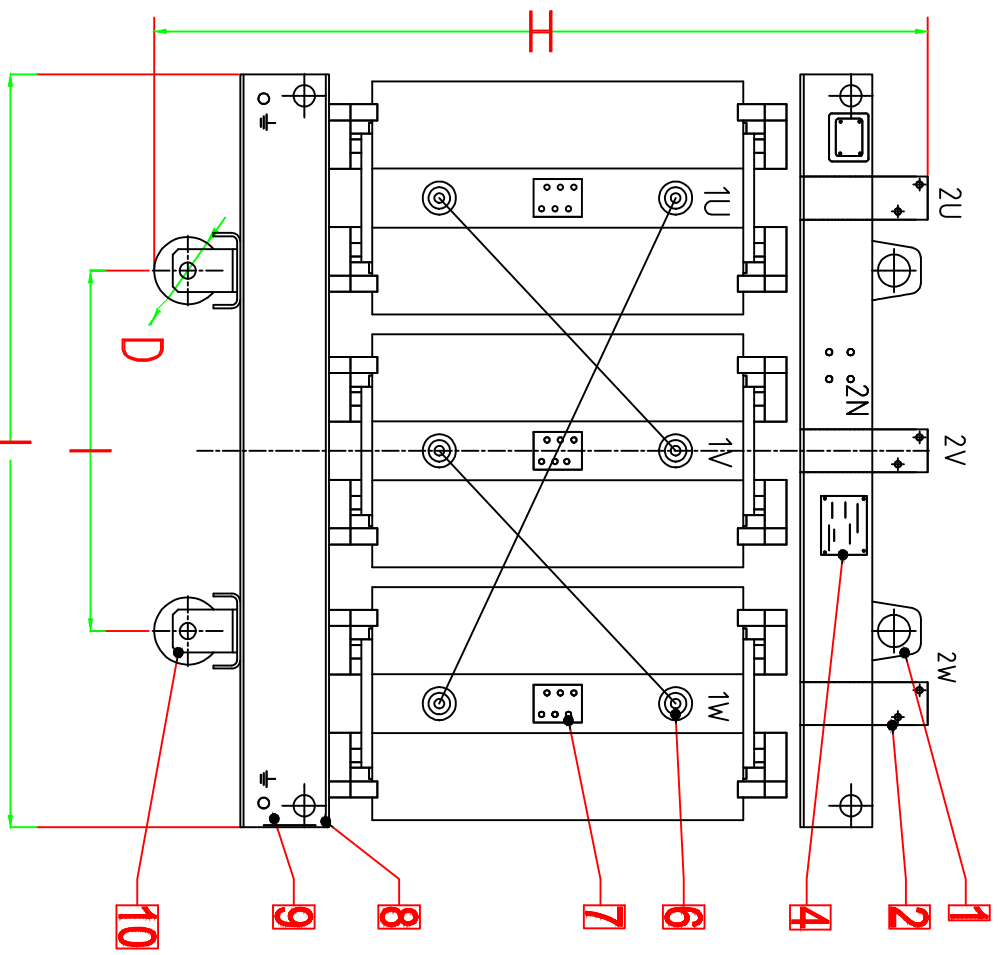

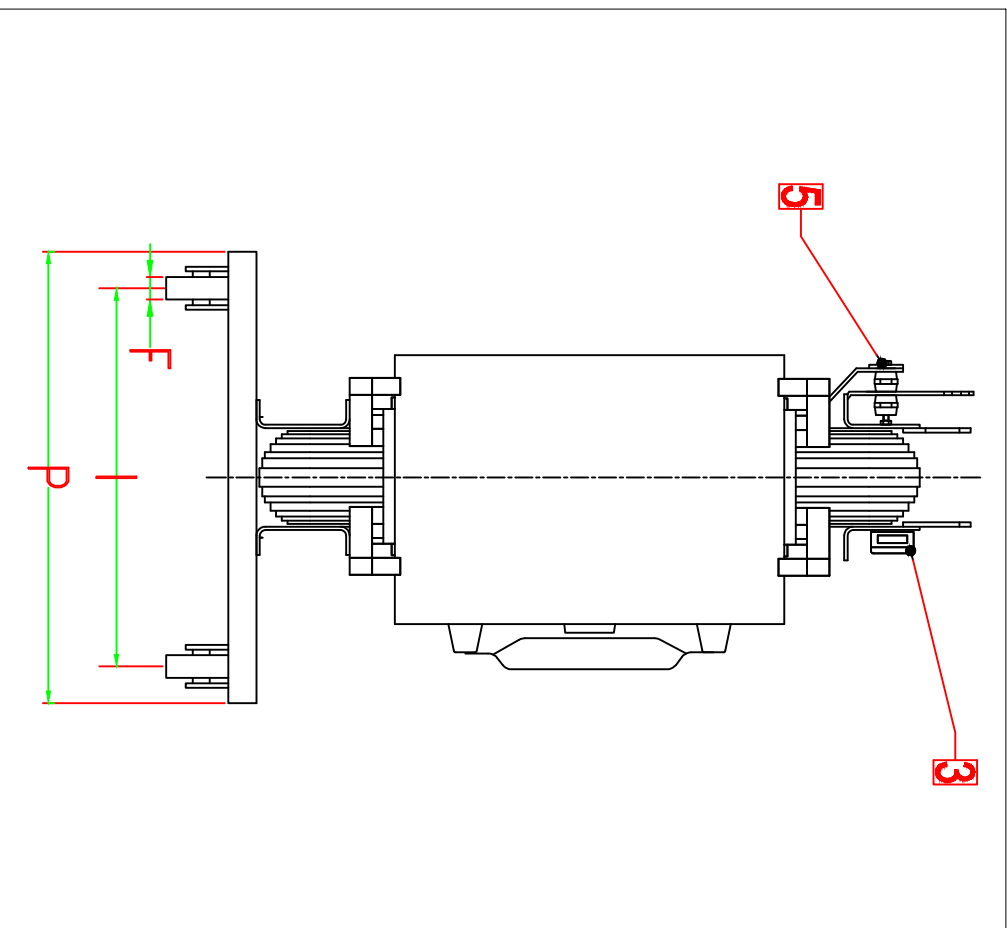

Pos. 7 - No Scala

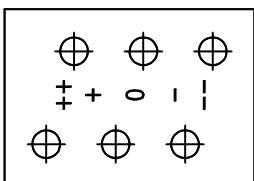

Pos.	Descrizione / Description	N°
1	Golfari di sollevamento / Lifting lugs	4
2	Terminale B. T. / Low voltage terminal	3
3	Scatola connessioni / Connection box	1
4	Targa caratteristiche / Rating plate	1
5	Terminale neutro / Neutral terminal	1
6	Terminale primario / High voltage terminal	3
7	Morsetteria variazione 1° / Variation clamp 1°	3
8	Attracchi per traino / Couplers	8
9	Morsetto di messa a terra / Earthing clamp	2
10	Carrello reversibile / Trolley for shifting	2

Description / Descrizione	Value
Raffreddamento / Cooling	AN
Potenza / Power	50 kVA
Tensioni / Voltage	11/0,4/16 kV
Gruppo / Connection Sym.	Dyn11
Frequenza / Frequency	50 Hz
Peso Totale / Total weight	490

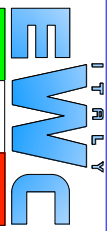

REVISIONE	00	EMMISSIONE	T. AL-SALIH	ELABORATO	T. AL-SALIH	CONTROLLATO	T. AL-SALIH	APPROVATO	T. AL-SALIH
DATA									

EWC GROUP srl

GENERIC	COMMESSA
CODICE	
FILE	FILE
FILE	FILE
DESCRIZIONE	09340
	2
	2

A TORNARE IN LEGGE DI RIFORMA LA PROPRIETA' DI QUESTI SEGNI CON DIRITTO DI BREVETTO O DI TERZO O DI UN'ALTRA COMUNITA' SECONDO LE LEGGI E LE ORDINANZE IN MATERIA DI BREVETTI E PATENTI. TUTTI I DIRITTI SONO RISERVATI. EWC GROUP S.R.L. E' UN'AZIENDA A MEMBRI. LE INFORMAZIONI SULLA NOSTRA ATTIVITA' SONO SU WWW.EWC-GRUP.COM. PER INFORMAZIONI SULLA NOSTRA ATTIVITA' E' POSSIBILE CONTATTARCI AL NUMERO 02 7600 4164.